

the L.A.S.S. Edition

June 2016

President's Message

By Wilson Hardy

Rain and then windstorms and then hail... So much for this spring and any time to fly. If you did find time to test the air where can we fly? Wow what a rotten start to this year. OK, so let's take a step back and look at the options available. We can still fly in the state parks on the dams for some sloping we can still make the long trip to other AMA fields and fly as visitors we can still legally fly non-powered aircraft in the city parks. That makes for some work, but it is possible.

What I'm telling you is don't give up. We can make it through these next couple of years. In the meantime it may be time to thin the population in the hanger. Look at some more ambitious projects and by the time we have a field again maybe we will see some truly spectacular planes that took more than one building season to finish.

I know I'm not one to talk. It seems that I can never get the freedom of an afternoon or evening to just build. My workshop is a disaster and I can't even get into it. Oh wait... I just found that project to fill the time between rainstorms. Time to dig out and regroup. If this is how life is treating you, keep your chin up. You are not alone. We are all in this together. Keep looking up.

Next CLUB MEETING

Tuesday, June 7

7:30 p.m.

Willard Community Center

Folsom & West B Street

Lincoln, NE

Next Scheduled Meet after Current - Aug. 2

Meeting Notes

By Tom Wild

President Wilson Hardy called the April 5, 2016 LASS meeting to order at 7:34 pm .

OLD BUSINESS:

A Boy Scout flying demo was mentioned and that Jim Baker was the "go to" for information on this demo. Also the possibility of a club fun fly was brought up but no dates (or locations) were discussed.

NEW BUSINESS:

Many of us received an email from Jim Baker that the Lancaster Event Center field lease would not be renewed for 2016. Their dirt mining could be considered a safety issue and possibly the reason we are being denied the field use.

Darin Kelstrom had sent an email to Jim about the possibility of using the open field on the west side of Pioneer Park. Jim had contacted Andrea at the Pioneer Park Nature Center who said this area is a nature preserve, and they have already had issues with drones.

Wilson used to fly at Wagon Trail Lake off the spillway on the east side of the dam without any conflict. He will contact Game and Parks to see if that is OK and if they know of any other area we could use. Bruce Jones asked how large of area is ideal for thermal flying and Allan Worrest stated a 1000' circle is idea for an AMA contest.

Jim stated there is a large grass area between the Firth NE retirement home and a lake (Big Nemaha Reservoir) that might belong to the retirement home and Bruce Jones said he would try to find out who owned this land.

Loren Blinde was unable to attend but sent the following email, *"Not sure if we still need or want membership cards, given that we've only had them because of the Event center. If the club still wants them, I'd be glad to print a new set without reference to the Event center and mail them if needed."*

Minutes (Continued on page 2)

Minutes (Continued from page 1)

If the field discussion turns to Mead as a possibility, my opinion is that it is suitable for winch or hi-starts only during designated events or when the wind is just right and can be staked south of the field. Otherwise it would be impractical on the runway if others are flying. Great place for electricians though (and the food is usually pretty good too)."

It was mentioned that the area of the old LSK field at 33rd and Superior still had an open field between the VW dealership and Salt Creek.

Darin mentioned there is a sod farm at 27th and Saltillo, he would stop in and ask if we could fly there. Thane Kirchhoff reminded us to keep in mind we need to stay 5 miles from an airport and away from flight lines.

MODEL OF THE MONTH:

Allan brought in his 2.5 meter Avia, electric glider kit from Top Model CZ.

The meeting adjourned around 8:15 pm with 10 members present.

Firth

As Bruce Jones doesn't expect to attend the next meeting, he asked that the following message be forwarded to the membership. Concerning a possible flying site near Firth, he wrote on May 5:

The possible flying site at the east edge of Firth measures five, count 'em five acres that include the owner's house and outbuilding. Bordered immediately on the east by woods that are posted No Trespassing. On the west by residences.

Please forward to the membership. Seems kinda small to me.

Regional Events

- 6/4-5 **Lincoln Sky Knights** June Fun Fly. LSK field Waverly, NE (See attachment)
- 6/17-19 **Grand Island, NE (A)** GI MODELERS RC EXHIBITION. Site: Husker Hwy & Alda Rd. Dennis Tjaden CD PH: 308.384.2754 Email: dtjaden@kdsi.net. Visit: grandislandmodelers.com. Sanction #16/37. Primitive camping available. 540' Petromat runway, 800' grass, airconditioned clubhouse, aircraft storage sunshade. Food & drinks available on-site. Pilot prizes and raffles. \$20 landing fee.
- 6/23-26 **Council Bluffs, IA (C)** 2016 CORNHUCKFEST. Site: The Field. Robert English CD PH: (402) 331-2357 Email: renglishjr@aol.com. Visit: metrorcflying.com. Sanction #16/685. The Twin City Eagles Squadron announce the 6th annual CornHuckfest of the Midwest. The event will be held at "the Field" located in Council Bluffs, IA. More info at cornhuckfest.com. Sponsor: TWIN CITIES EAGLE SQUADRON
- 6/24-25 **Cedar Rapids, IA (C)** RCMA SAILPLANE FUN FLY. Site: Cr/Linn Co Solid Waste Agency. Robert Wendel CD PH: 319-364-6594 Email: kf0xb@imonmail.com. Visit: rockwellcollinsclubs.com/clubs-ia.model-aviator. Sanction #16/883. Soar virtually all points of the compass, from the highest point in Cedar Rapids. Open flying both days. Sponsor: ROCKWELL COLLINS MODEL AVIATOR
- 6/25 **Western R/C Flyers Old Timers Fun Fly with Glider Fly** - Starts at 9:00 am with flying until 3:00 pm, Mead, NE
- 7/16 **Western R/C Flyers Old Timers Fun Fly with Glider Fly** - Starts at 9:00 am with flying until 3:00 pm, Mead, NE



The Lincoln Area Soaring Society, chartered by the Academy of Model Aeronautics as club #1853, publishes this newsletter. Any material in it may be reprinted without permission provided credit is given to LASS and the article author. Submit articles to the editor at the E-mail AWorrest@aol.com

President: Wilson Hardy
Secretary: Steve Dworsky

Treasurer: Jim Baker
Editor: Allan Worrest

AVIA

By Allan Worrest

Topmodel CZ manufactures numerous conventional and electric model sailplanes and the Avia is one of them. While online companies like SoaringUSA, Icare-Ikarus and Aloft Hobbies sell some of their line, Esprit Tech/Models may have the largest selection. I purchased my Avia from Esprit as they seem to be the only place that sold one not already covered. With age, I'm beginning to find transparent colors are more difficult to see at a distance than the opaque.

The Avia sports a V-tail. For those who don't like V-tails, Topmodel CZ makes the Prelude which is identical to the Avia but has a mid-located conventional stabilizer. There is an extensive Prelude thread on RCGroups. A less extensive one exists for the Avia.

I brought the Avia to the April meeting was to show the wings before they were covered with opaque film. The wing is a built-up construction with balsa ribs attached to a carbon fiber tube acting as a main spar. If the ribs are spaced too far apart and not glued well to the spar, as was the case with one of my previous sailplanes, the wings will flutter and burst. The Avia rib spacing is closer and in addition there are half ribs in between the full ribs. I expect the Avia wing will be stronger than that other model.

ELECTRO SAILPLANE



Manufactured by:
TOPMODEL CZ
679 05 HABRŮVKA 100 - CZECH REPUBLIC
www.topmodelcz.cz
e-mail: info@topmodelcz.cz

Order N°: 02082

Radio system you'll need :



1310mm

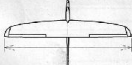

2500mm

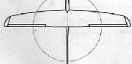

46dm²
23,9-28,4g/dm²



1,1 - 1,3 kg



5channel
with
6 servos



XPower XC 3514/12
Axi 2814/12



2S-3S Lixx 2-3Ah



MH 32 mod.

*Není-li uvedeno jinak, všechny
neoznačené míry jsou v milimetrech
UNLES STATED, ALL DIMENSIONS
ARE IN MILIMETERS*

LSK Annual Fun Fly
Lincoln Sky Knight Field
134th and Waverly Road
June 4th & 5th

Gates open at 9:00 am

Gas grill available for use.

Sport, Scale, Twins, 3D, electrics, whatever participants are ready to fly.
Contact me about requests for special events and I will plan a time slot if
needed, otherwise it will be open flying.

Visitors welcome. AMA required to fly but not required to be a spectator.
Sky Knight Field has two 450' by 40' runways, one paved, one grass.
Large clubhouse with covered deck and two large sun shelters.
We also have a free camping area with power.

NO FLYING OVER PIT AREA, PARKING LOT, OR SPECTATORS

Bring drinking water and a lawn chair.

Contest Director
Leonard Akert
Cell: 402-326-5970
rakert@neb.rr.com

For map and more information:

<http://www.lincolnskyknights.org>

http://metrorcflying.com/metro_area_schedule.htm

GPS: 40.931607, -96.537702